



Alfa Laval ThinkTop V50 and V70

Control

Introduction

ThinkTop V50 and V70 takes valve control to a new level and all these new features are available on any Alfa Laval diaphragm, butterfly, single-seat and mixproof valves. While helping to increase production performance and secure traceability, ThinkTop V50 and V70 provide real-time information on the valve's operating status 24/7.

Both ThinkTop V50 and V70 are interchangeable with prior ThinkTop versions, and the appropriate variant is selected based on the number of solenoid valves. With only one sensor target and included adapter, ThinkTop V50 and V70 are easily retrofittable to existing Alfa Laval valves.

ThinkTop V50 and V70 come fitted with features such as Auto Setup, Live Setup and Flex Setup that streamline the setup process, making it quick and easy. Auto Setup and Live Setup recognise the valve based on its DNA profile and can complete the valve setup without any manual interaction.

The burst seat clean function is available on ThinkTop V70. This function controls the optimum seat pulse sequence of the valve, making it possible to achieve up to 90% CIP liquid savings for each seat lift.

Application

ThinkTop V50 and V70 are designed for use in the dairy, food, beverage, and biopharma industries.

Benefits

- Auto setup
- Automatic valve recognition
- Automatic selection of tolerance band
- Fast, Live and Flex Setup
- 360-degree LED indication
- Burst seat clean
- Exchangeable (threaded) air-fittings
- Interchangeable with ThinkTop classics

Working principles

The control unit offers a single sensor solution for diaphragm, butterfly, single-seat and mixproof valves and it can be fitted with up to three solenoid valves. ThinkTop converts the electrical PLC output signals into mechanical energy to energise, or de-energise, the air-operated valve, using the physical sensor target mounted on the valve stem.



Installation with Auto Setup or Live Setup is intuitive and fast. To initiate Auto Setup, simply press the "SELECT" button and then the "ENTER" button to begin the setup sequence. The ThinkTop automatically recognizes the type of valve and completes the programming sequence fast and efficiently. Alternatively, the ThinkTop can be set up, without dismantling the control head, using the built-in Live Setup feature for remote-configuration.

Certificates



Dimensions (mm)

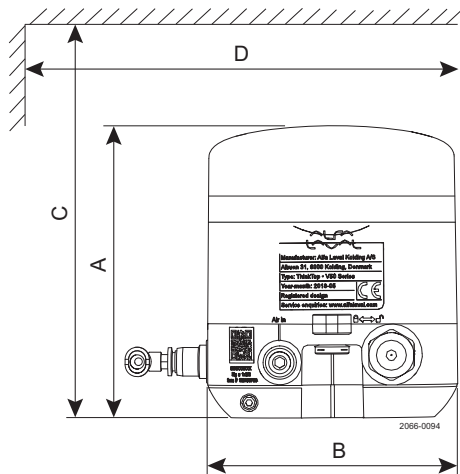

Figure1. ThinkTop V 50

	mm	Inch
A	123	4.84
B	105	4.13
C	200	7.87
D	150	5.91

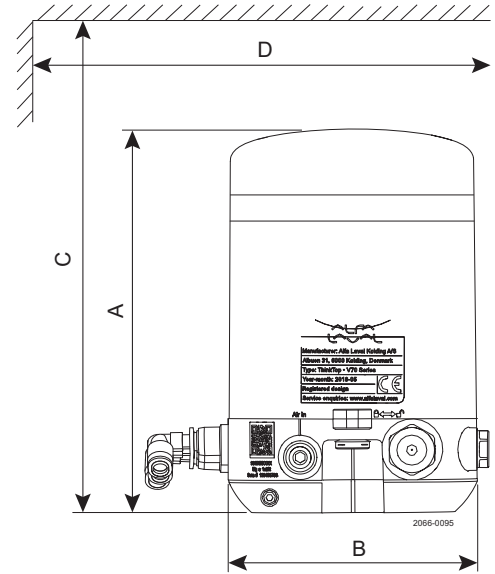

Figure2. ThinkTop V 70

	mm	Inch
A	164	6.45
B	105	4.13
C	250	9.84
D	170	6.69

TECHNICAL DATA

Material	
Plastic parts	Nylon PA 12
Steel parts	1.4301 / 304
Air fittings	Nickel plated / Nylon PA6
Gaskets	Nitril / NBR
Environment	
Working temperature	-10°C to +60°C
Protection class (IP)	IP66, IP67 and IP69K
Protection class (NEMA)	4, 4X and 6P
Hazardous area	ATEX and IECEx in preparation
Control board	
Communication	See interfaces section
Sensor accuracy	± 0,1 mm
V50 – Valve stem length	Below < 65 mm
V70 – Valve stem length	Above > 65 mm
Mean Time To Failure (MTTF)	224 years
Approvals	UL/CSA Certificate: E174191

Solenoid valve	
Supply voltage	24 VDC ± 10%
Nominal power	0,3 W
Air supply	300-900 kPa (3-8 bar)
Type of solenoids	3/2-ways or 5/2-way
Number of solenoids	0-3
Manual hold override	Yes
Air pressure	6-8 bar
Air quality	Class 3,3,3 acc. DIN ISO 8573-1
B10 data	5 Million cycles
Recommendation	Operate once a month to prevent dry-out

Air fitting	
Throttle function air inlet/outlet	0-100%
Threaded air fitting G1/8	6 mm (Rim blue) or 1/4" (Rim Grey)
Elbow push-in fittings	6 mm (Rim blue) or 1/4" (Rim Grey)

Cable connection	
Main cable gland entry Digital	M16 (ø4 - ø10 mm) (0,16" - 0,39")
Main cable gland entry AS-I	M16 (ø2 - ø7 mm) (0,08" - 0,28")
Seat lift sensor cable gland entry	M12 (ø3,5 - ø7 mm) (0,14" - 0,28")
Max wire diameter	0.75 mm2 (AWG20)

Vibration	
Vibration	18 Hz-1kHz @ 7,54g RMS
Shock	100g

Humidity	
Constant humidity	+40°C, 21 days, 93% R.H.
Cyclic humidity (working)	-25°C/+55°C, 12 cycles 93% R.H.





Accessories by functionality	
Upper seat lift surveillance	Kit
Valve speed reduction	0-100%
Valve closing speed increase	Quick air exhaust, ø6 mm
Solenoid valve protection	Supply air filter 1/8", avoid clogging of solenoid valves

OPERATIONAL DATA

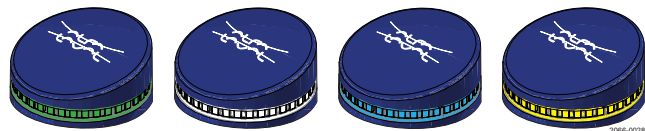
LED indication

ThinkTop features a 360-degree light guide. When the sensor target is within the respective setup position band, the corresponding colour lights up.



Valve position									
Actuator		All		Main valve open		Upper seat lift		Lower seat push	Between
		De-energised		Energised		Energised		Energised	
Not setup		Green flashing		White flashing		Blue flashing		Yellow flashing	off
Factory									
ThinkTop V Mode									
setting									
Operation		Green		White		Blue		Yellow	off
Not OK		Green / red flashing		White / red flashing		Blue / red flashing		Yellow / red flashing	Red Flashing

Auto setup

Auto Setup is a rule-based function. If one of these rules are not present, Flex Setup must be used.

By default, ThinkTop V50 and V70 uses the de-Energised/Energised paradigm for valve positions feedback.

Parameter	Auto Setup/Live Setup	Flex Setup (retrofit mode)
Status feedback (OK or error)	Valve state (Fail safe signal)	Status error
Seat cleaning function	Enabled	Disabled
Valve operation monitor	Enabled	Disabled
Ext. sensor operation monitor	Enabled	Disabled
Interlock	Enabled	Disabled
Output (AS-i master input)	Special	Special
External sensor masking	Enabled	Disabled

Valve compatibility chart

	Common applications (Auto / Live Setup)	Special applications (Flex Setup)	Incompatible valves
ThinkTop V50	Single Seat valves		
	Small Single Seat valve		
	Butterfly valves		
	Diaphragm valves		
	Ball valves		
ThinkTop V70	Shutter valves		
	Double seat valves		
	Double seal valve		
	In addition to the ThinkTop V50 valves		
	Double seat valves		
ThinkTop V70	Double seal valve		
	Long stroke single seat valves		
	Air/Air valves		

- ThinkTop classic retrofit mode or alternative setup with no restrictions
- Feedback structure such as the open/closed valve feedback
- SSV type 200 and 300 NO (DN /ISO) maintainable, need to be setup as a rotary valve
- Application with no solenoid valve, feedback indication only
- One control unit to control multiple valves

- Valves without raising stem and mushrooms
- Regulating valves
- Safety valves
- Sample valves
- SMP-EC
- 700 series
- Other valve brands

3.9.3 Overview of connectors and ports

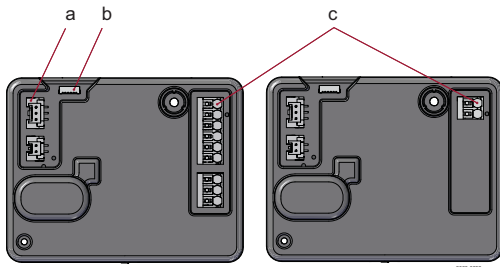

- a: Solenoid valve connector
- b: Indication lamp
- c: Main terminals

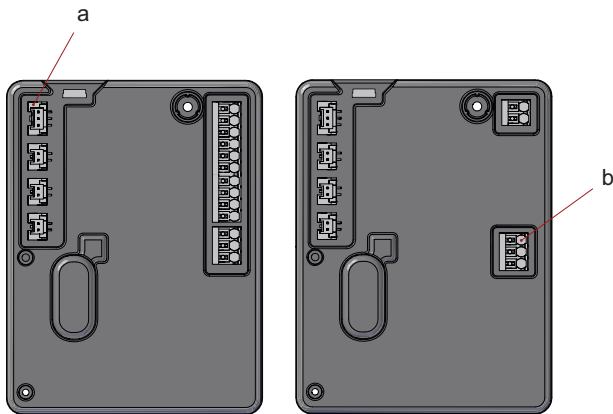

- a: Diagnostic Port
- b: Seat lift sensor terminal

Burst clean mode

Burst seat clean mode is available for ThinkTop V70 and can be enabled when a ThinkTop V70 with 2 or 3 solenoid valves is setup successfully using Auto Setup.

The burst seat clean mode is enabled or disabled via the ThinkTop V70 control board. Press "SELECT" (4 times) until LED no 4 flashes, and then press 'ENTER' to enable or disable. This option is also available as an adjustable IO-Link parameter.

The burst seat clean option is from factory disabled by default. However, if it is enabled and there is a manual reset to factory default, the burst seat clean option is disabled.

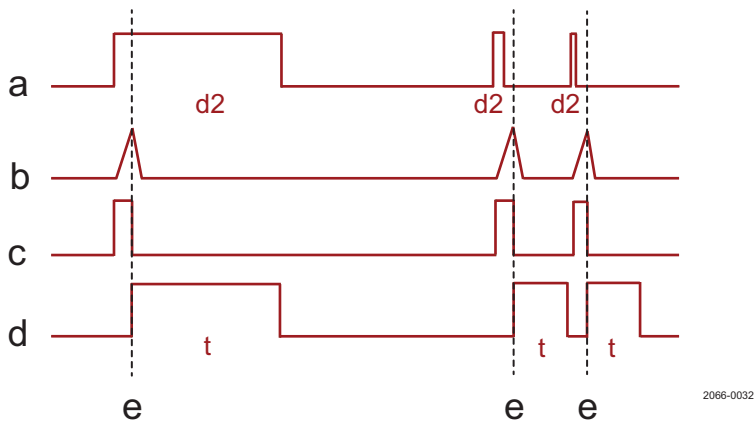

a: Input (from PLC)

b: Position

c: Solenoidvalve output

d: Output minimum 2 sec. (both visual and electrical)

e: Position reached

When the PLC input signal for either upper or lower seat push (Usl, Lsp) goes high, the respective solenoid valve is Energised.

As soon as the sensor target reaches the predefined energised valve position, the solenoid valve is automatically de-energised by the ThinkTop V70.

A two-second electrical and visual feedback (t) is provided as a handshake for successful completion of a burst seat pulse. The PLC input duration must be at least 500 ms (d).

If ThinkTop V70 is set up using Auto Setup without the upper seat lift sensor, the function uses the stored setup stroke time for "Lower seat push" plus some extra time for when the solenoid valve is deactivated.

Water consumption graph

ThinkTop V70 CIP liquid consumption during Burst seat clean on different Mixproof valves, provided with 6 bar air pressure:

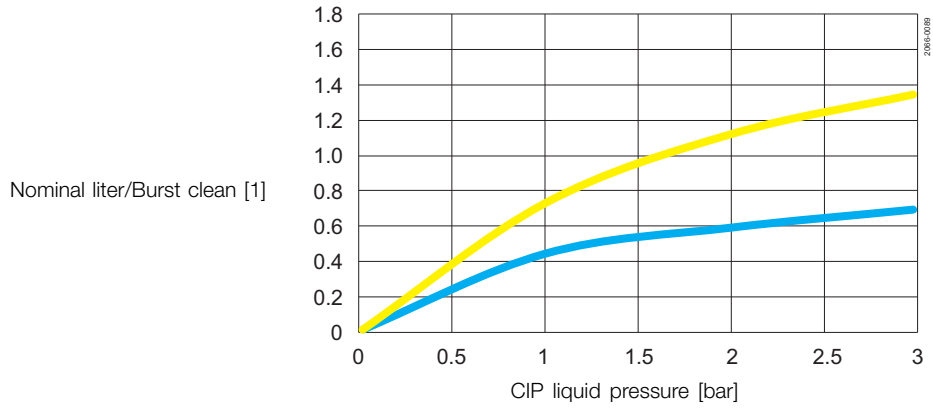

Figure3. Unique Mixproof valve / Unique CP-3 Mixproof valve 1.5" DN 40 and 2" DN50

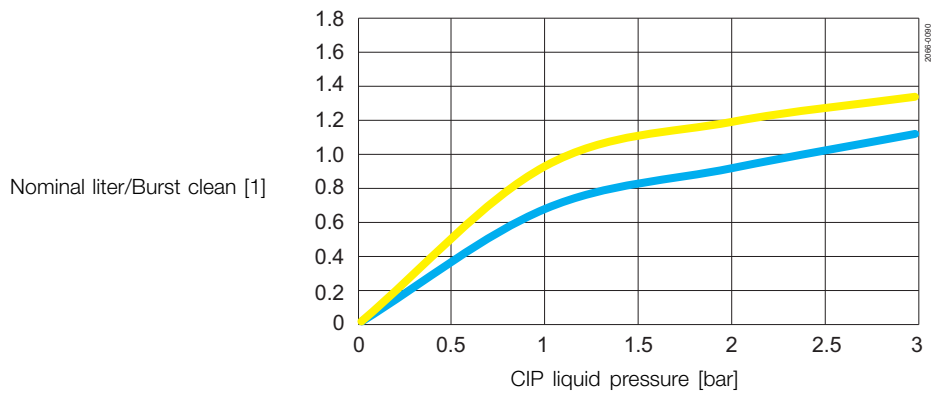

Figure4. Unique Mixproof valve / Unique CP-3 Mixproof valve 2.5" DN65 and 3" DN80

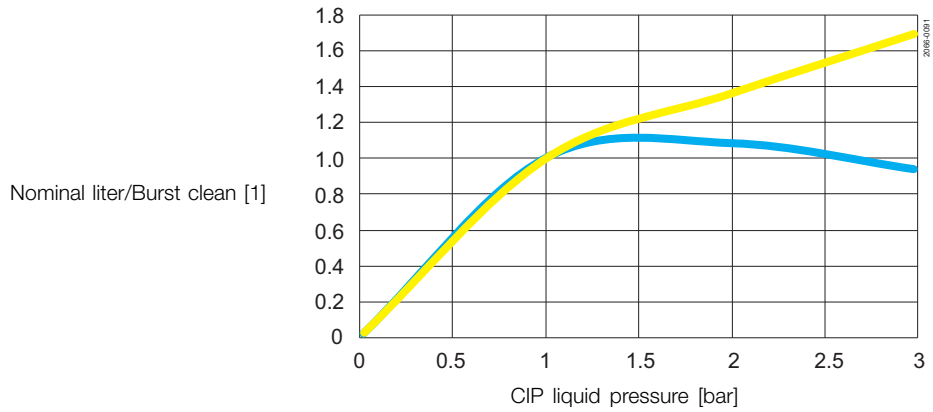

Figure5. Unique Mixproof valve / Unique CP-3 Mixproof valve 4" DN100

- Lower Seat Push
- Upper Seat Lift

Valve state – Fail safe signal

The following table gives an overview of behaviour per Error condition where the valve state signal goes low. Further description of the various Error conditions can be found in the ThinkTop Instruction Manual, section 5.2.

Valve state is a decentralized functionality, available for all ThinkTop variants and a feature that can be used for monitoring process issues or to ease and simplify the PLC programming of a valve surveillance.

Error Code #	Error description	ThinkTop Digital	ThinkTop AS-Interface	ThinkTop IO-Link
		Valve state FAIL SAFE SIGNAL behaviour	Not Available DE-ENERGIZED SIGNAL behaviour	Valve state FAIL SAFE SIGNAL behaviour
15	Key lock active	na	na	na
16	Sensor target missing	Drops low	Drops low	Drops low
17	Setup missing peripherals	na	na	na
18	Pneumatic part issue	na	na	na
19	Seat lift sensor issue	Drops low	Drops low	Drops low
20	Position not reached	Drops low	Drops low	Drops low
21	Unexpected valve movement	Drops low	Drops low	Drops low
22	Seat-lift sensor missing	Drops low	Drops low	Drops low
23	Solenoid valve 1 missing	Drops low	No effect	Drops low
24	Solenoid valve 2 missing	Drops low	No effect	Drops low
25	Solenoid valve 3 missing	Drops low	No effect	Drops low
26	Interlock warning	Drops low	No effect	Drops low
27	Hardware fault	Drops low	No effect	Drops low
28	Setup aborted	na	na	na
29	Blocked button	Drops low	No effect	Drops low
30	Voltage Low	Drops low	No effect	Drops low
31	Safety stop	Drops low	Drops low	Drops low

Default bitmapping

The default settings apply to both Digital, AS-Interface and IO-Link

ThinkTop V50 truth signal table: default factory setting

	DE-EN (I0) close	MAIN (I1) open	Valve state (Fail safe signal)
DE-EN (No active SV)	1	0	1
MAIN SV1 active (O1)	0	1	1

ThinkTop V70 truth signal table: default factory setting

	DE-EN (I0) all closed	MAIN (I1) open	USL (I2) open	LSP (I3) open	Valve state (Fail safe signal)
DE-EN (No active SV)					
Both seats closed					
Lower seat in closed position	1	0	0	0	1
Upper seat in closed position					
MAIN SV1 active (O1)					
Lower seat in open valve position	0	1	0	0	1
Upper seat not closed					
USL SV2 active (O2)					
Upper seat not close	0	0	1	0	1
Lower seat in closed position					
LSP SV3 active (O3)					
Lower seat in seat push position	0	0	0	1	1
Upper seat in closed position					

U.S.A. compliance option

Applies to both Digital Interface and AS-Interface, and ThinkTop V70 variants only. The U.S.A. compliance option refers to a bitmapping interface used in the USA on Mixproof valves, fitted with 3 solenoid valves. This U.S.A. bitmapping can be enabled after or before auto setup.

U.S. regulations require independent closed position feedback signals for upper seat lift and lower seat push in a Mixproof valve application.

The U.S.A. bitmapping are enabled or disabled on the ThinkTop V70 control board. Press "SELECT" (5 times) until LED no 8 flashes, and then press "ENTER" to enable or disable. This option is also available as an adjustable IO-Link parameter.

The U.S.A. compliance option is from factory disabled by default. However, if it is enabled and there is a manual reset to factory default, the U.S.A. compliance option remains enabled.

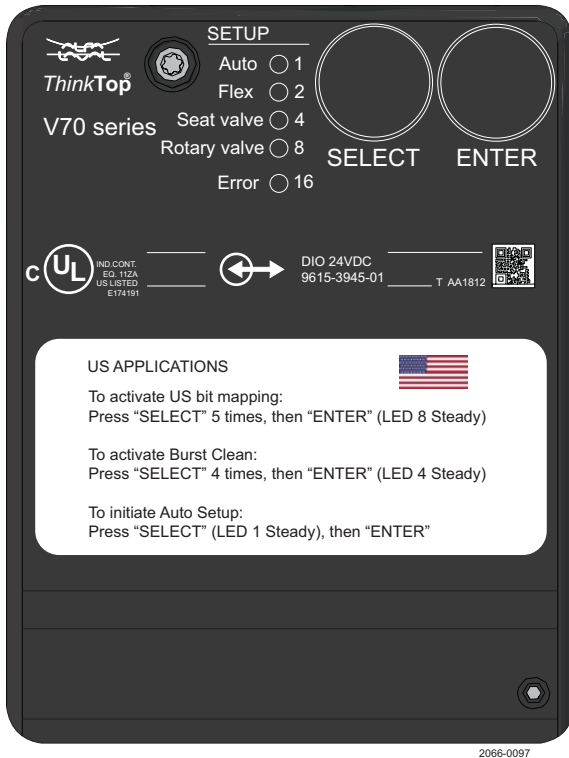

U.S.A. bitmapping

The information in the table is based on the following setup:

- ThinkTop V70 with 3 solenoid valves
- IFT series seat lift sensor of the type NO or NC
- Mixproof valve with both seats installed (balanced or unbalanced upper plug)
- Any combination of above valve type and sensor type

	DE-EN (I0)	MAIN (I1)	USL (I2)	LSP (I3)	Valve state (Fail safe signal)
DE-EN (No active SV)	Both closed	open	closed	closed	
Both seats closed	1	0	1	1	1
Lower seat in closed position					
Upper seat in closed position					
MAIN SV1 active (O1)					
Lower seat in open valve position	0	1	0	0	1
Upper seat not closed					
USL SV2 active (O2)					
Upper seat not closed	0	0	0	1	1
Lower seat in closed position					
LSP SV3 active (O3)					
Lower seat in seat push position	0	0	1	0	1
Upper seat in closed position					

Digital interface

ThinkTop Digital 24V DC

Device name	ThinkTop V50 24V Digital ThinkTop V70 24V Digital
Voltage supply	<ul style="list-style-type: none">24 VDC \pm 10%; according to EN 61131-2
Protection	<ul style="list-style-type: none">Reverse polarity (24 VDC \pm 10%); EN 61131-2Voltage interruption and brown-out; EN61131Short circuit; EN 61131
Current consumption	<ul style="list-style-type: none">Nominal 30mA (Idle)
Outputs to PLC	<ul style="list-style-type: none">Max 100mA (solenoid valve and seat lift sensor active)
PLC input card	<ul style="list-style-type: none">Max rated 24V/100A
UL supply	<ul style="list-style-type: none">Class 2 according to cULus
Voltage drop	<ul style="list-style-type: none">Typical 3V at 50 mA
Terminal type	<ul style="list-style-type: none">Spring force push-in technologySupports nominal wire cross-section between 1.0 mm² [17AWG] and 0.30 mm² [22AWG]Supports wire and ferrules for wire cross-section of 0.75 mm² [18AWG] with pin length 12 mm



Electrical connections

ThinkTop V50

Terminals	Control board	Colour code wires
1	24V	BN (brown)
2	GND	BU (blue)
3	out: Status	WH (white)
4	out: DE-EN	BK (black)
5	out: EN. Main valve	GY (grey)
6	in: SV1. Main valve	PK (pink)

ThinkTop V70

Terminals	Control board	Colour code wires
1	24V	BN (brown)
2	GND	BU (blue)
3	out: Status	WH (white)
4	out: DE-EN	BK (black)
5	out: EN. Main valve	GY (grey)
6	out: USL. Upper seat lift	PK (pink)
7	out: LSP. Lower seat push	VT (violet)
8	in SV1. Main valve	OG (orange)
9	in SV2. Upper seat lift	GY/PK (grey/pink)
10	in SV3. Lower seat push	WH/BU (white/blue)
Seat lift sensor		
E1	L+	BN (brown)
E2	GND	BU (blue)
E3	Signal	BK and WH (black and white)

ThinkTop V50

M12 option (8-pin A-coded plug)

Pin numbers and terminal numbers are aligned

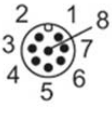
M12 Chassis plug connector	Control board Terminal numbers	M12 pin numbers wire colors
	1: 24V	Pin 1: BN (brown)
	2: GND	Pin 3: BU (blue)
	3: out: Status	Pin 2: WH (white)
	4: out: DE-EN	Pin 4: BK (black)
	5: out: EN. Main valve	Pin 5: GY (grey)
	6: in SV1. Main valve	Pin 6: PK (pink)
	7: nc	-
	8: nc	-

ThinkTop V70

M12 option (12-pin A-coded plug)

Pin numbers and terminal numbers are aligned

M12 Chassis plug connector	Control board Terminal numbers	M12 pin numbers wire colors
	1: 24V	Pin 1: BN (brown)
	2: GND	Pin 3: BU (blue)
	3: out: Status	Pin 2: WH (white)
	4: out: DE-EN	Pin 4: BK (black)
	5: out: EN. Main valve	Pin 5: GY (grey)
	6: out: USL Upper seat lift	Pin 6: PK (pink)
	7: out: LSP Lower seat push	Pin 7: VT (violet)
	8: in SV1. Main valve	Pin 8: YE (yellow)
	9: in SV2. Upper seat lift	Pin 9: GN (green)
	10: in SV3. Lower seat push	Pin 10: RD (red)
	11: nc	-
	12: nc	-

AS-Interface

ThinkTop AS-Interface

Device name	ThinkTop V50 ASI2 & ThinkTop V50 ASI3 ThinkTop V70 ASI2 & ThinkTop V70 ASI3
Supply voltage	<ul style="list-style-type: none"> AS-Interface 29.5 – 31.6 VDC
Protection	<ul style="list-style-type: none"> Reverse polarity (24 VDC \pm 10%); EN 61131-2 Voltage interruption and brown-out; EN 61131 Short circuit; EN 61131
Current consumption	<ul style="list-style-type: none"> Nominal: 30 mA (idle) Max 100 mA (solenoid valve and seat lift sensor active)
Terminal type	<ul style="list-style-type: none"> Spring force push-in technology Supports nominal wire cross-section between 1.0 mm² [17AWG] and 0.30 mm² [22AWG] Supports wire and ferrules for wire cross-section of 0.75 mm² [18AWG] with pin length 12 mm
AS-I specification v2.11	<ul style="list-style-type: none"> Supports standard addressing and are compatible with M0-M4 AS-I master profiles, allows up to 31 nodes on an AS-I network Slave profile = 7FFF
AS-I specification v3.0	<ul style="list-style-type: none"> Supports extended A/B addressing and is compatible with M4 AS-I master profile, allows up to 62 nodes on an AS-I network Slave profile = 7A77
AS-I addressing	<ul style="list-style-type: none"> Default slave address (Node) is = 0 Address (Node) changes with a standard handheld AS-I addressing device or via AS-I Master Gateway



AS-Interface bit table

For the AS-Interface versions, the following bit assignment will be used

PLC system / Gateway Output table	ThinkTop V50	ThinkTop V70
Toggle Burst clean	O0	O0
SV1. Main valve	O1	O1
SV2. Upper seat lift	nc	O2
SV3. Lower seat push	nc	O3

PLC system / Gateway	ThinkTop V50	ThinkTop V70
Input table		
DE-EN	I0	I0
EN. Main valve	I1	I1
Upper seat lift	nc	I2
Lower seat push	nc	I3

Electrical connections

ThinkTop V50

Terminal	Control board	Colour code wires
1	AS-i +	BN (brown)
2	AS-i -	BU (blue)

ThinkTop V70

Terminal	Control board	Colour code wires
1	AS-i +	BN (brown)
2	AS-i -	BU (blue)
	Seat lift sensor	
E1	L+	BN (brown)
E2	GND	BU (blue)
E3	Signal	BK (black) and WH (white)

ThinkTop V50 and ThinkTop V70

M12 option (4-pin A-coded plug)

Pin numbers and terminal numbers are aligned

M12 Chassis plug connector	Control board Terminal numbers Functions	M12 pin assignments wire colours
	1: AS-i +	Pin 1: BN (brown)
	2: nc	-
	3: AS-i -	Pin 3: BU (blue)
	4: nc	-

IO-Link interface

ThinkTop IO-Link

In addition to process indication and control, the IO-Link variant enables diagnostic information and features additional functionality that is unique to ThinkTop

Device name	ThinkTop V50 IOL ThinkTop V70 IOL
IO-Link supply voltage	<ul style="list-style-type: none"> 24 VDC \pm 10%; according to EN 61131-2
Protection	<ul style="list-style-type: none"> Reverse polarity (24 VDC \pm 10%); EN 61131-2 Voltage interruption and brown-out; EN61131 Short circuit; EN 61131
Current consumption	<ul style="list-style-type: none"> Nominal: 30 mA (idle) Max 100 mA (solenoid valve and seat lift sensor active)
Terminal type	<ul style="list-style-type: none"> Spring force push-in technology Supports nominal wire cross-section between 1.0 mm² [17AWG] and 0.30 mm² [22AWG] Supports wire and ferrules for wire cross-section of 0.75 mm² [18AWG] with pin length 12 mm
Download of IO-Link files	<ul style="list-style-type: none"> Alfa Laval Anytime and ThinkTop configurator Go to www.alfalaval.com ThinkTop and documentation Go to www.io-link.com Click IODDfinder and key ThinkTop
IO-Link interface tool	<ul style="list-style-type: none"> IFM E30390 IO-Link Interface / USB IO-Link master IFM LR Device – Line recorder
ThinkTop V50 IO-Link Interface Description	<ul style="list-style-type: none"> alfalaval-000001....pdf
ThinkTop V70 IO-Link Interface Description	<ul style="list-style-type: none"> alfalaval-000002....pdf
Cable length to IO-Link master	<ul style="list-style-type: none"> Max 20 meters
Transmission rate	<ul style="list-style-type: none"> COM 2 (38.4 kBaud)
Minimum cycle time	<ul style="list-style-type: none"> 5 ms
Data storage	<ul style="list-style-type: none"> yes
Profiles	<ul style="list-style-type: none"> na
SIO mode	<ul style="list-style-type: none"> no
Port class	<ul style="list-style-type: none"> A



IO-Link data table

For the IO-Link version, the bit assignment and diagnostic data can be found in the manual "IO-Link Interface Description" for ThinkTop V50 and ThinkTop V70 respectively go to www.alfalaval.com ThinkTop V and documentation.

On ThinkTop V50 and ThinkTop V70 control board, using the IO-Link interface tool from IFM, all parameter settings and visualisation data are available through the diagnostic connection port.

From the "IO-Link Interface Description" the table below shows an overview of the data storage (not all parameters included). When replacing a ThinkTop V on a process plant, some data are re-stored, included in the new ThinkTop V, and other data must be reassigned again, excluded in the new ThinkTop V.

Included	Excluded
Customization <ul style="list-style-type: none"> • Application Specific Tag • Function Tag • Location Tag • Power Save • Burst Clean • USA bitmapping • RGB colour 	Control board ID <ul style="list-style-type: none"> • Vendor Name • Vendor Text • Product Name • Product ID • Product Text • Serial Number • Hardware Version • Firmware Version • Prod Date
	Setup data <ul style="list-style-type: none"> • Setup positions • Setup state
	Diagnostics <ul style="list-style-type: none"> • SV-activations • SV-ON_time • PV-SetupStrokeEn • PV-SetupStrokeDeEn • PressureShockCnt • Temp • Log

Electrical connections

ThinkTop V50

Terminal	Control board	Colour code wires
1	L +24V	BN (brown)
2	L -GND	BU (blue)
3	IO-Link signal	BK (black)

ThinkTop V70

Terminal	Control board	Colour code wires
1	L +24V	BN (brown)
2	L -GND	BU (blue)
3	IO-Link signal	BK (black)
Seat lift sensor		
E1	L+	BN (brown)
E2	GND	BU (blue)
E3	Signal	BK (black) and WH (white)

ThinkTop V50 and V70

M12 option (4-pin A-coded plug)

Pin numbers and terminal numbers are aligned

M12 Chassis plug connector	Control board Terminal numbers	M12 pin assignments wire colours
	1: L +	Pin 1: BN (brown)
	2: nc	-
	3: L -	Pin 3: BU (blue)
	4: Out1	Pin 4: BK (black)

Alfa Laval reserves the right to change specifications without prior notification.

How to contact Alfa Laval

Contact details for all countries are continually updated on our website. Please visit www.alfalaval.com to access the information direct.